

POWERTEC i250C STANDARD POWERTEC i250C ADVANCED POWERTEC i320C STANDARD POWERTEC i320C ADVANCED

Spare Parts.....	2
Figure A: Powertec i250C/i320C STD/ADV Machine Assembly	2
Figure B: Powertec i250C/i320C STD/ADV Inside Machine Assembly	3
Figure C: Powertec i250C/i320C STD/ADV Wire Drive Assembly	4
Figure D: Powertec i250C/i320C STD Front Assembly	4
Figure E: Powertec i250C/i320C ADV Front Assembly	5
Electrical Schematic	6



Lincoln Electric Bester Sp. z o.o.
ul. Jana III Sobieskiego 19A, 58-263 Bielawa, Poland
www.lincolnelectric.eu

Spare Parts

SP50430, SP50431, SP50432, SP50433 REV05

ASSEMBLY PAGE NAME			Powertec Machine Assembly	Machine Front Assembly	Wire Drive Assembly & Euro Socket Assembly	Powertec i250C/i320C STD Front Assembly	Powertec i250C/i320C ADV Front Assembly	Miscellaneous Items
CODE NO.:	K NO.:	FIGURE NO.:	A	B	C	D	E	-
50430	K14157-1	POWERTEC i250C STANDARD	1	1	1	1	-	1
50431	K14157-2	POWERTEC i250C ADVANCED	2	2	2	-	2	2
50432	K14158-1	POWERTEC i320C STANDARD	3	3	3	3	-	3
50433	K14158-2	POWERTEC i320C ADVANCED	4	4	4	-	4	4

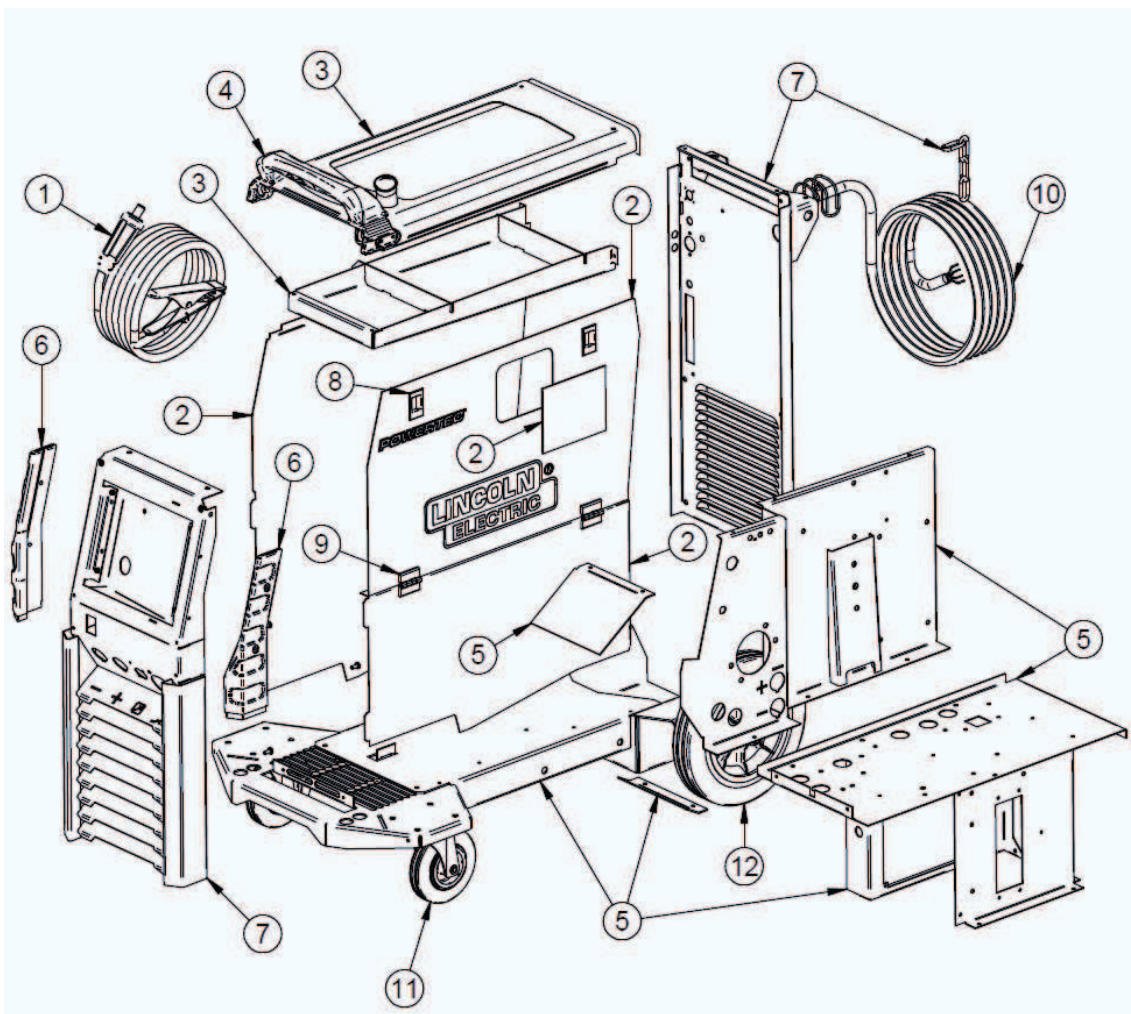

Figure A. Powertec i250C/i320C STD/ADV Machine Assembly

Item	Description	Part Number	QTY	1	2	3	4	5	6
1	WELDING CABLE	GRD-300A-50-5M	1	x	x	x	x		
2	SIDE PANEL KIT	R-1019-486-1R	1	x	x	x	x		
3	COVER KIT	R-3019-455-1/02R	1	x	x	x	x		
4	HANDLE	R-0010-292-1R	1	x	x	x	x		
5	BASE, PARTITION, SHELF KIT	R-3019-426-1R	1	x	x	x	x		
6	SIDE COVER KIT	R-0010-623-1R	1	x	x	x	x		
7	FRONT AND REAR PANEL KIT	R-8040-387-1R	1	x	x	x	x		

8	LOCK	0654-610-004R	2	x	x	x	x		
9	LEAF HINGE	0654-610-007R	2	x	x	x	x		
10	MAIN INPUT CORD	R-5041-497-1R	1	x	x	x	x		
11	WHEELS	1029-660-127R	2	x	x	x	x		
12	WHEELS	1029-660-250R	2	x	x	x	x		

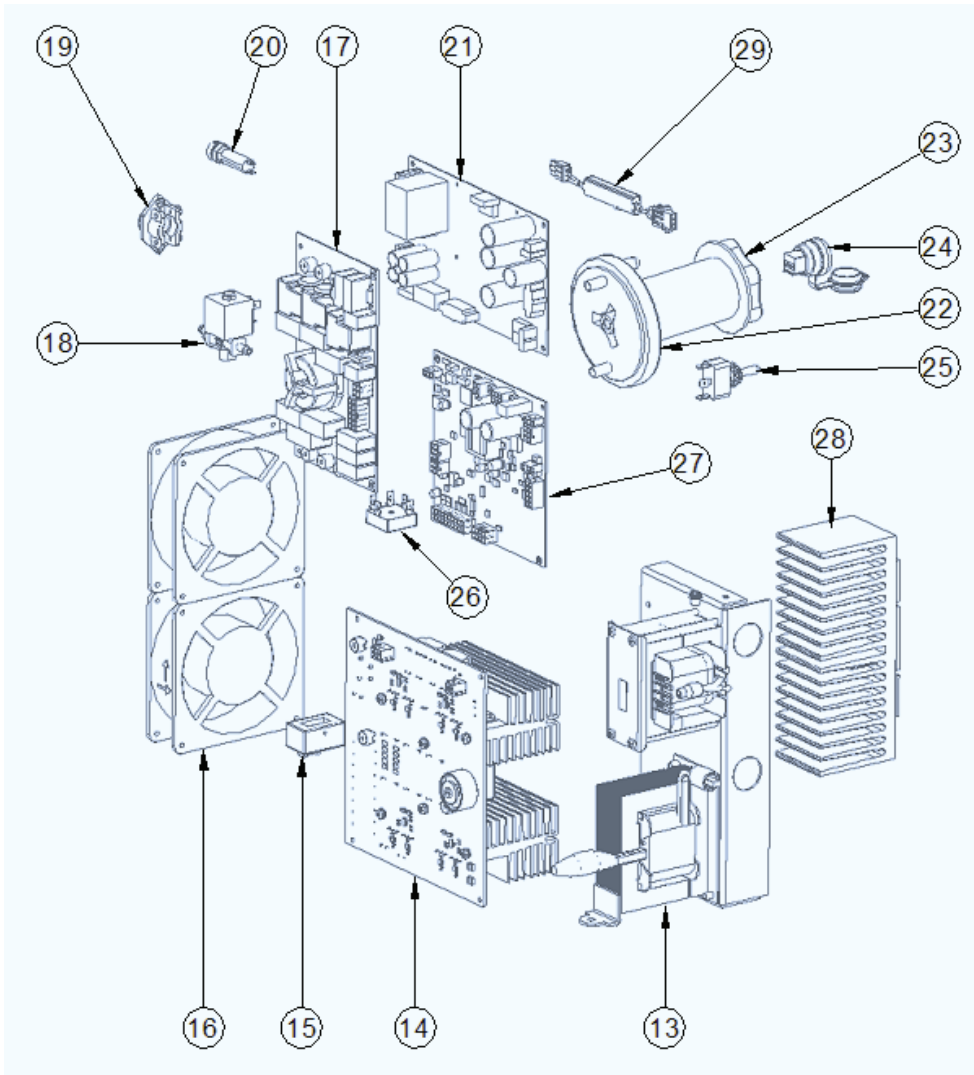

Figure B: Powertec i250C/i320C STD/ADV Inside Machine Assembly

Item	Description	Part Number	QTY	1	2	3	4	5	6
13	TRANSFORMER AND CHOKE	R-8040-382-2R	1	X	X	X	X		
14	INVERTER BOARD	R-6042-079-1R	1	X	X	X	X		
15	HALL SENSOR	W4900004R	1	X	X	X	X		
16	FAN	W66X1369R	2	X	X	X	X		
17	INPUT FILTER	Y051-1R	1	X	X	X	X		
18	SOLENOID	0972-423-040R	1	X	X	X	X		
19	CABLE RELIEF	1361-599-674R	1	X	X	X	X		
20	FUSE SOCKET	1158-632-032R	1	x	x	x	x		
	FUSE 1A 400V	1158-660-003R	1	x	x	x	x		
21	PC BOARD	R-6042-081-1R	1	x	x	x	x		
22	WIRE SPOOL HUB	0744-000-335R	1	x	x	x	x		
23	PLASTIC NUT	0744-000-336R	1	x	x	x	x		
24	USB SOCKET	1158-641-061R	1	-	x	-	x		

25	SWITCH	1115-280-004R	1	x	x	x	x		
26	THREE PHASE BRIDGE	1156-112-206R	1	x	x	x	x		
27	CONTROL BOARD	R-6042-082-2R	1	x	-	-	-		
	CONTROL BOARD	R-6042-082-1R	1	-	x	-	-		
	CONTROL BOARD	R-6042-080-2R	1	-	-	x	-		
	CONTROL BOARD	R-6042-080-1R	1	-	-	-	x		
28	OUTPUT BRIDGE	R-8040-388-1R	1	x	x	x	x		
29	LED MODULE	R-5041-508-1R	2	x	x	x	x		

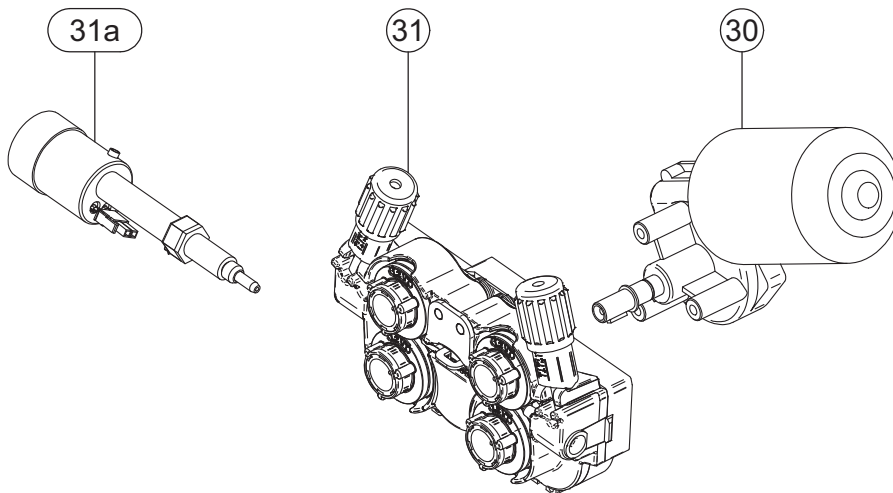

Figure C: Powertec i250C/i320C STD/ADV Wire Drive Assembly

Item	Description	Part Number	QTY	1	2	3	4	5	6
30	WIRE DRIVE MOTOR	1111-722-048R	1	X	X	X	X		
31	COMPLETE FEED PLATE ASSEMBLY (INCLUDES 1.0/1.2 MM DRIVE ROLLS AND WIRE GUIDE KIT)	0744-000-009R	1	X	X	X	X		
31a	Euro Socket	R-8040-389-1R	1	X	X	X	X		

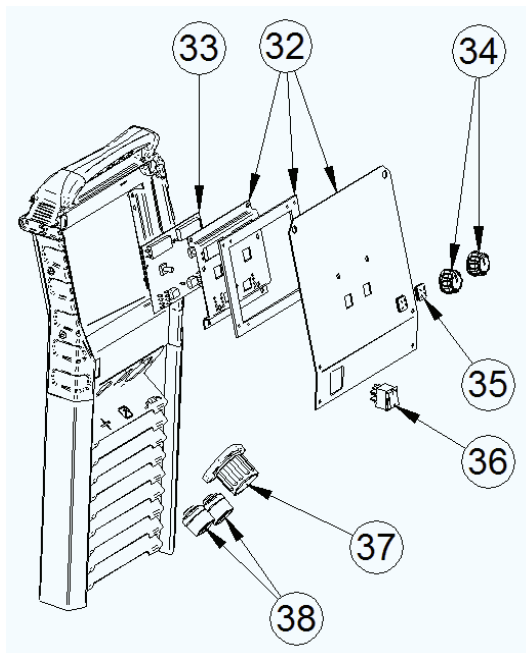

Figure D: Powertec i250C/i320C STD Front Assembly

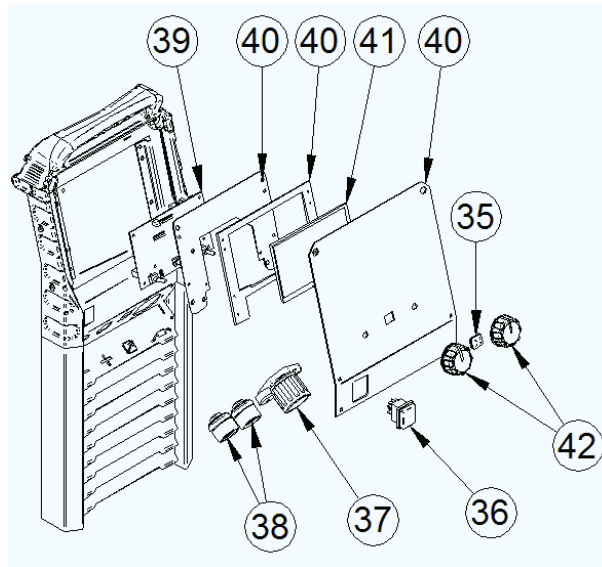

Figure E: Powertec i250C/i320C ADV Front Assembly

Item	Description	Part Number	QTY	1	2	3	4	5	6
32	DISPLAY FRONT PANEL KIT	R-0010-619-2R	1	X	-	X	-		
33	USER INTERFACE PCB	R-6042-078-1R	1	X	-	X	-		
34	KNOB	9SM22778-2	2	X	-	X	-		
35	BUTTON	9SS23055	2	X	-	X	-		
			1	-	X	-	X		
36	MAIN SWITCH	1115-270-022R	1	X	X	X	X		
37	EURO SLEEVE	C-1891-006-1R	1	X	X	X	X		
38	SOCKET	W7690350 R	2	X	X	X	X		
39	PCB	R-6042-077-1R	1	-	X	-	X		
40	DISPLAY FRONT PANEL KIT	R-0010-618-2R	1	-	X	-	X		
41	LCD	0942-177-002R	1	-	X	-	X		
42	KNOB	9SM22778-3	2	-	X	-	X		

Miscellaneous Items (not shown in figure A, B, C, D, E)

Item	Description	Part Number	QTY	1	2	3	4	5	6
43	HARNESSES KIT	R-5041-494-1R	1	X	X	X	X		



ECM Electronic®



Autoryzowany serwis spawarek oraz zgrzewarek krajowych i zagranicznych. Automatyka przemysłowa.

Nasze strony: www.spaw-serwisch.pl * ecm-electronic.pl

Dystrybucja, serwis, sprzedaż - kontakt:

e-mail: spawserwisch@gmail.com, biuro@ecm-electronic.pl

tel. kont.: +48 501 283 621, +48 34 368 1578 (z fax.)