

30x30x10 mm

2.5~5.5 CFM

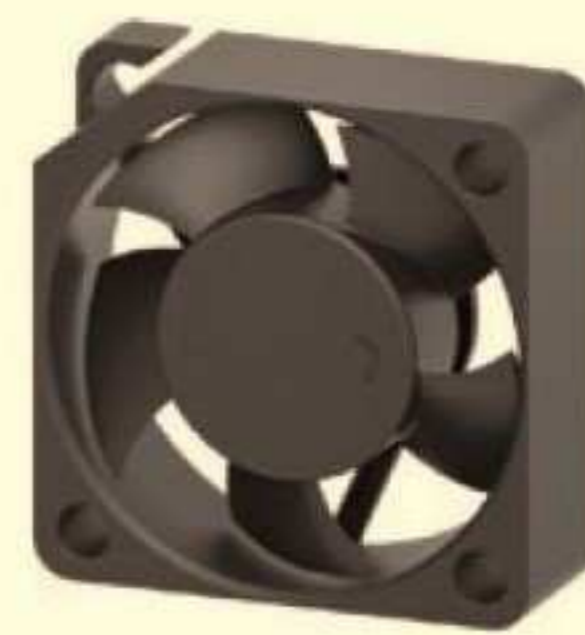

■ Specification

	Bearing	Rated Voltage	Power Current	Power Consumption	Speed	Airflow	Static Pressure	Noise	Weight	Curve
	● VAPO	(VDC)	(mA)	(WATTS)	(RPM)	(CFM)	(inch-H ₂ O)	(dB(A))	(g)	
MF30100V1-10000-A99	●	5	120	0.60	11000	5.5	0.20	23.0	7.8	2
MF30100V2-10000-A99	●	5	80	0.40	9500	4.7	0.17	21.0	7.8	3
MF30100V3-10000-A99	●	5	45	0.23	6000	2.5	0.07	10.2	7.8	5
MF30101V1-10000-A99	●	12	55	0.66	11500	5.5	0.25	23.0	7.8	1
MF30101V2-10000-A99	●	12	32	0.39	8600	4.6	0.14	20.0	7.8	4

■ Function (5V) R Type : F99 / F Type : G99 / PWM : H99, Q99, S99
(12V) R Type : F99 / F Type : G99

■ Air Flow-Static Pressure Characteristics

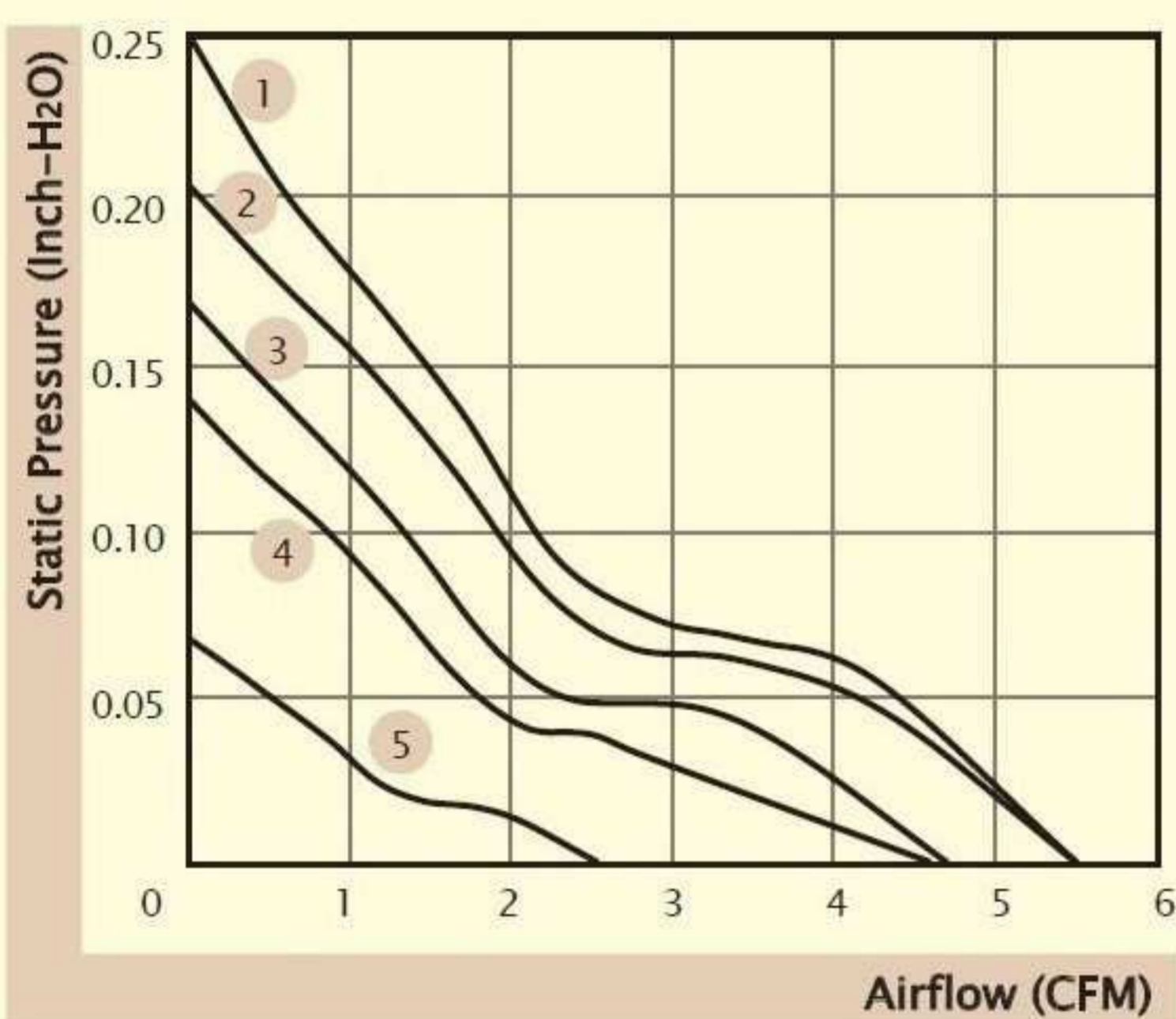

■ External Dimensions(mm)

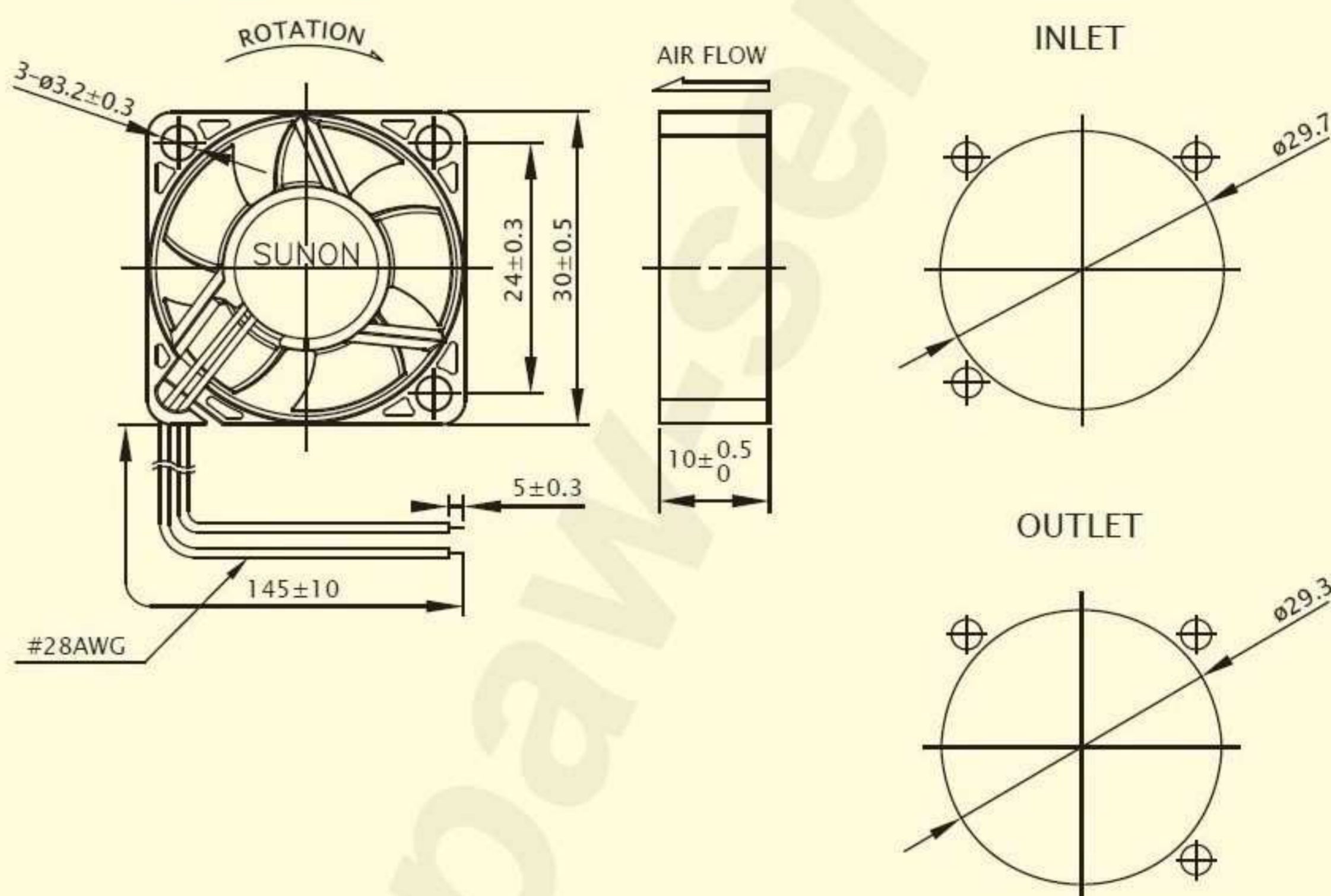

※ All model could be customized. Please contact with Sunon Sales.

※ Specifications are subject to change without notice. Please Visit SUNON website at www.sunon.com for update information.

■ RD / FG Output Signal

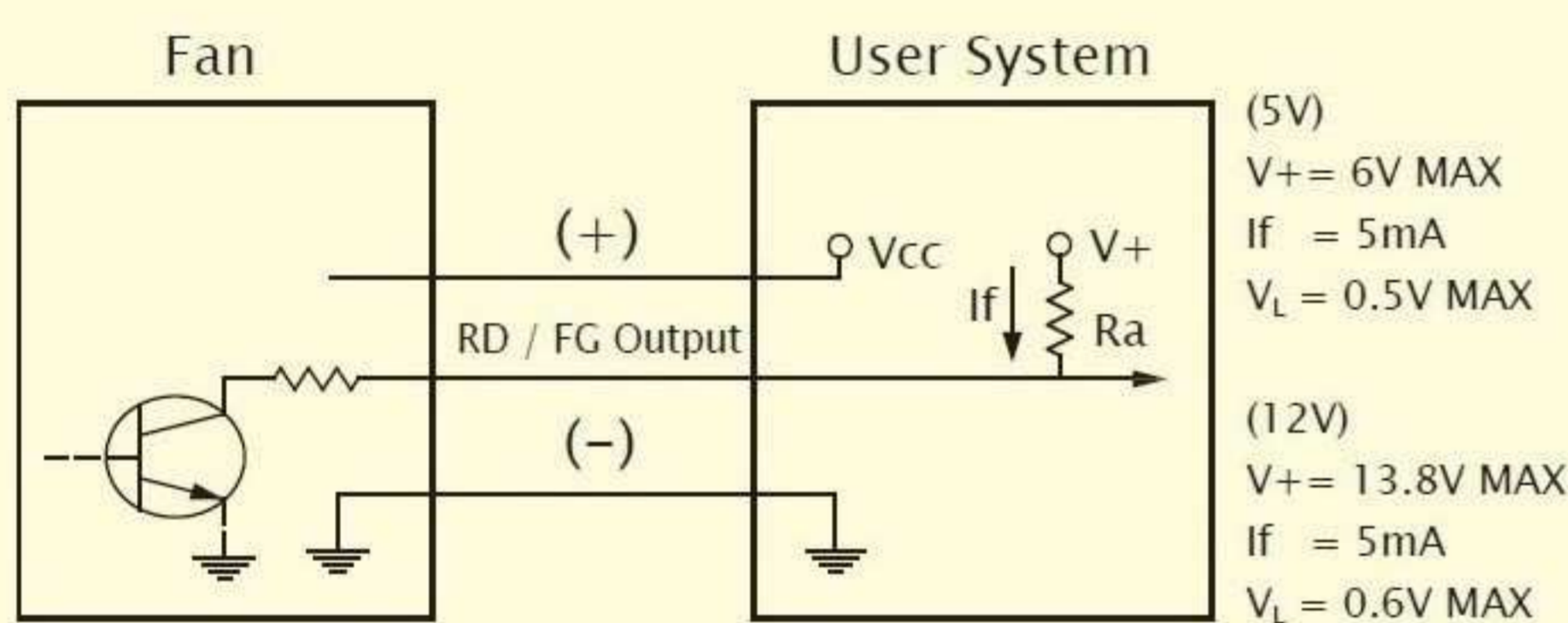

[RD Signal]

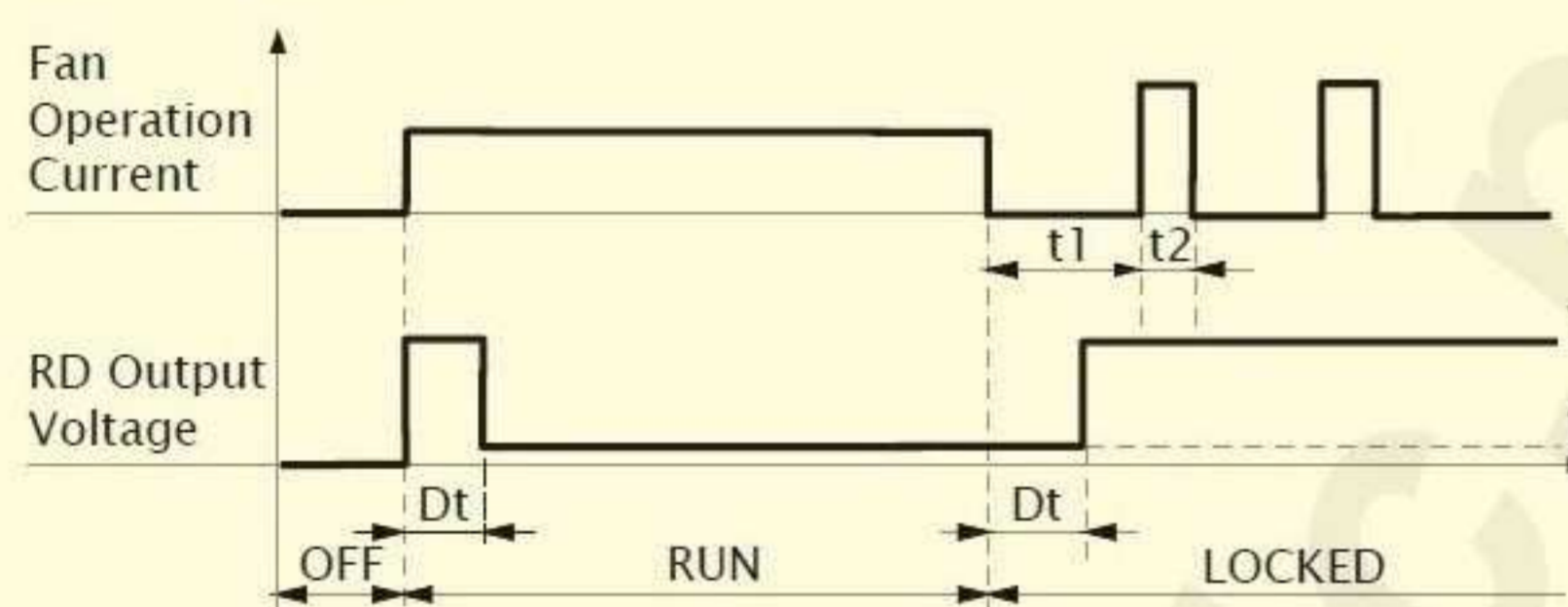

[FG Signal]

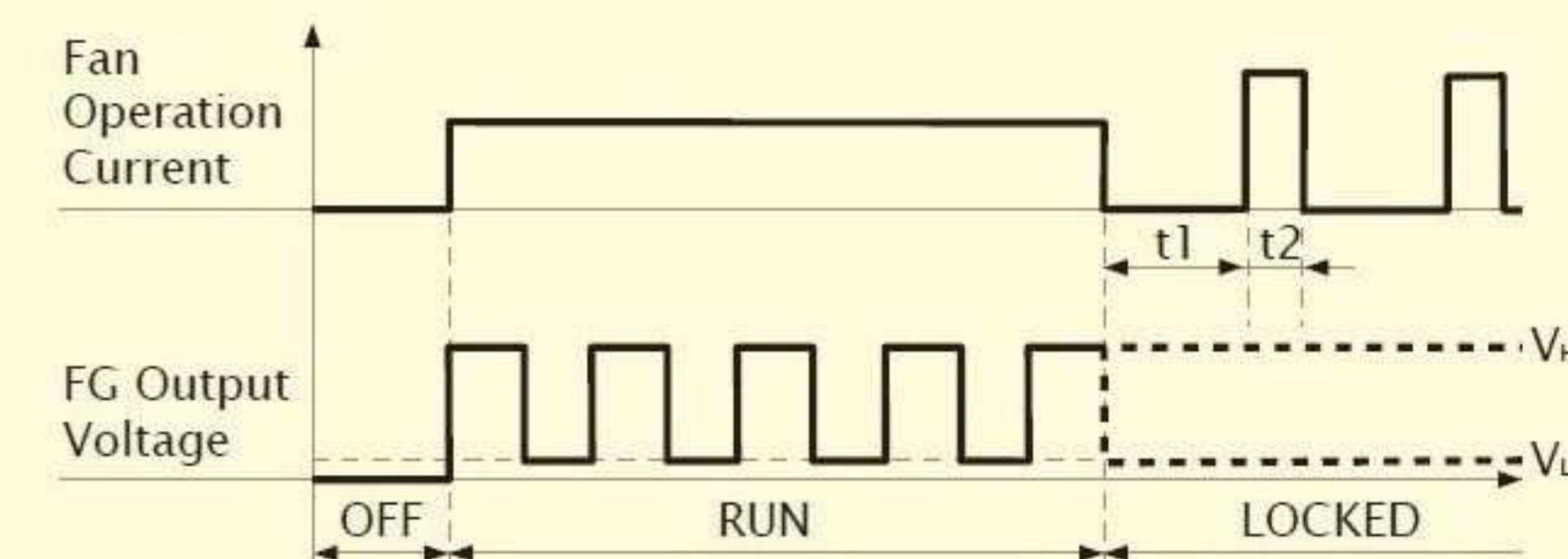
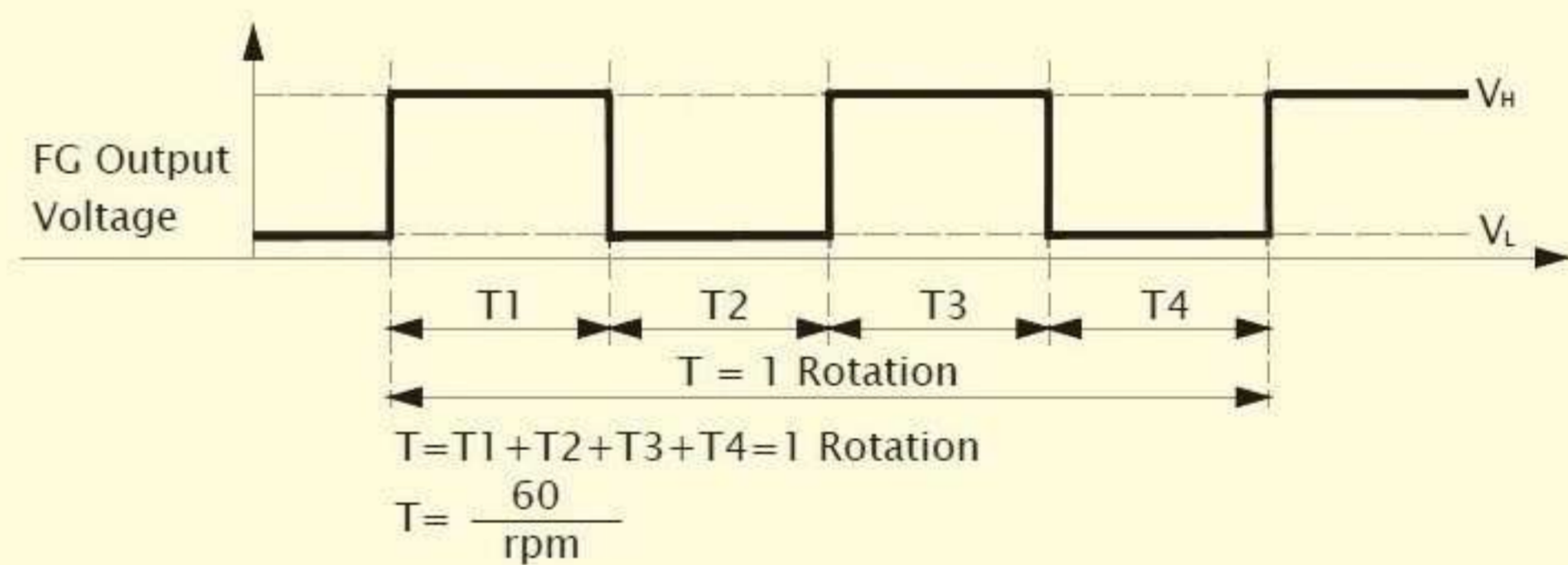

■ PWM Input Signal

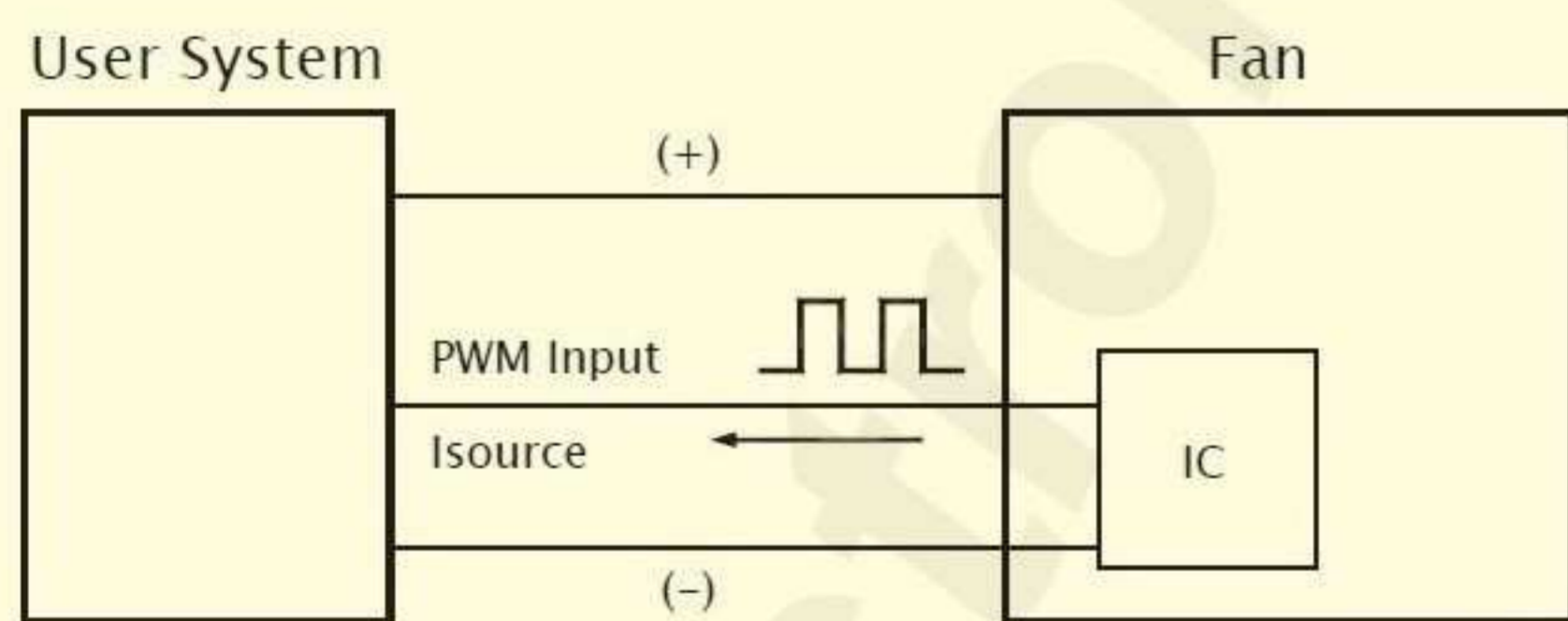

PWM FREQUENCY: 25KHZ
Isource=0.6mA at PWM Input Voltage 0V
The speed is default to be maximum if PWM input pin is unconnected.
Min. start up duty cycle is 20%.

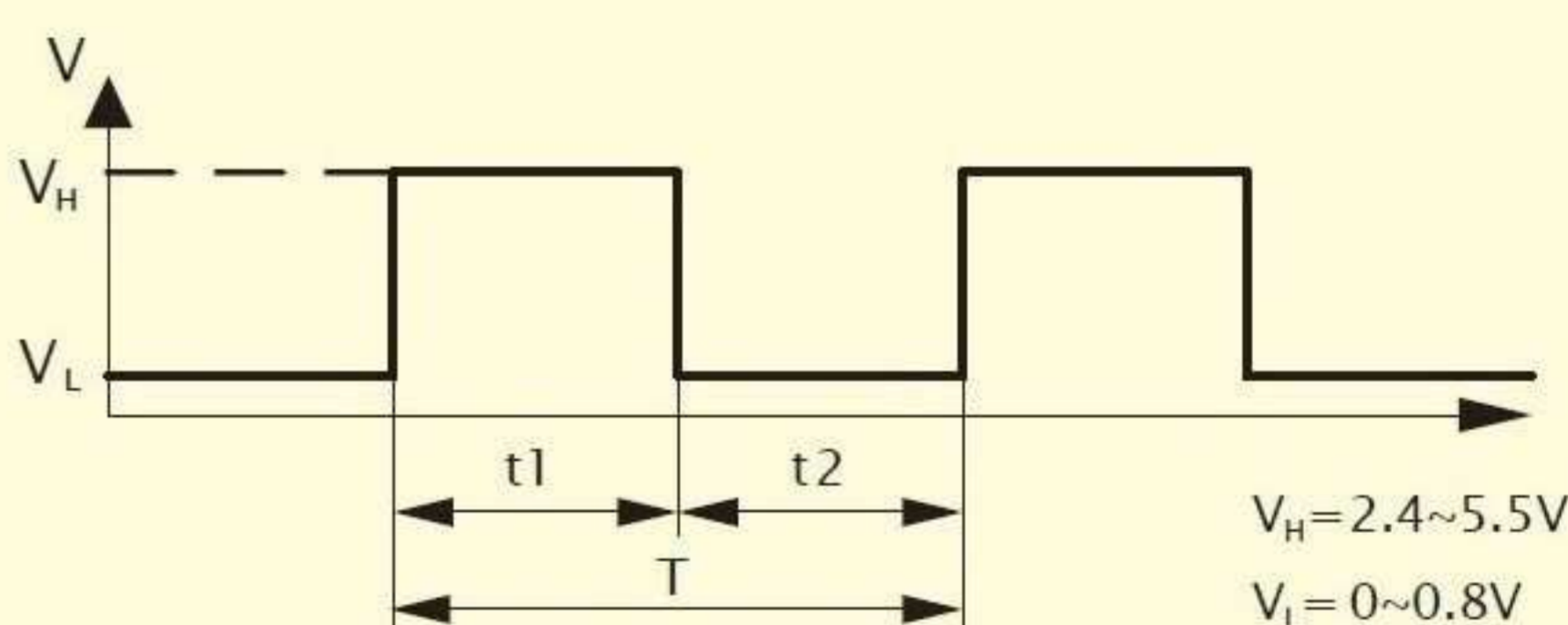

1. Period : $T = \frac{1}{f_{PWM}} = t1 + t2(\text{sec})$

2. Duty Cycle (D.C.) : $\frac{t1}{t1 + t2} \times 100 = \frac{t1}{T} \times 100(\%)$

■ PWM Curve

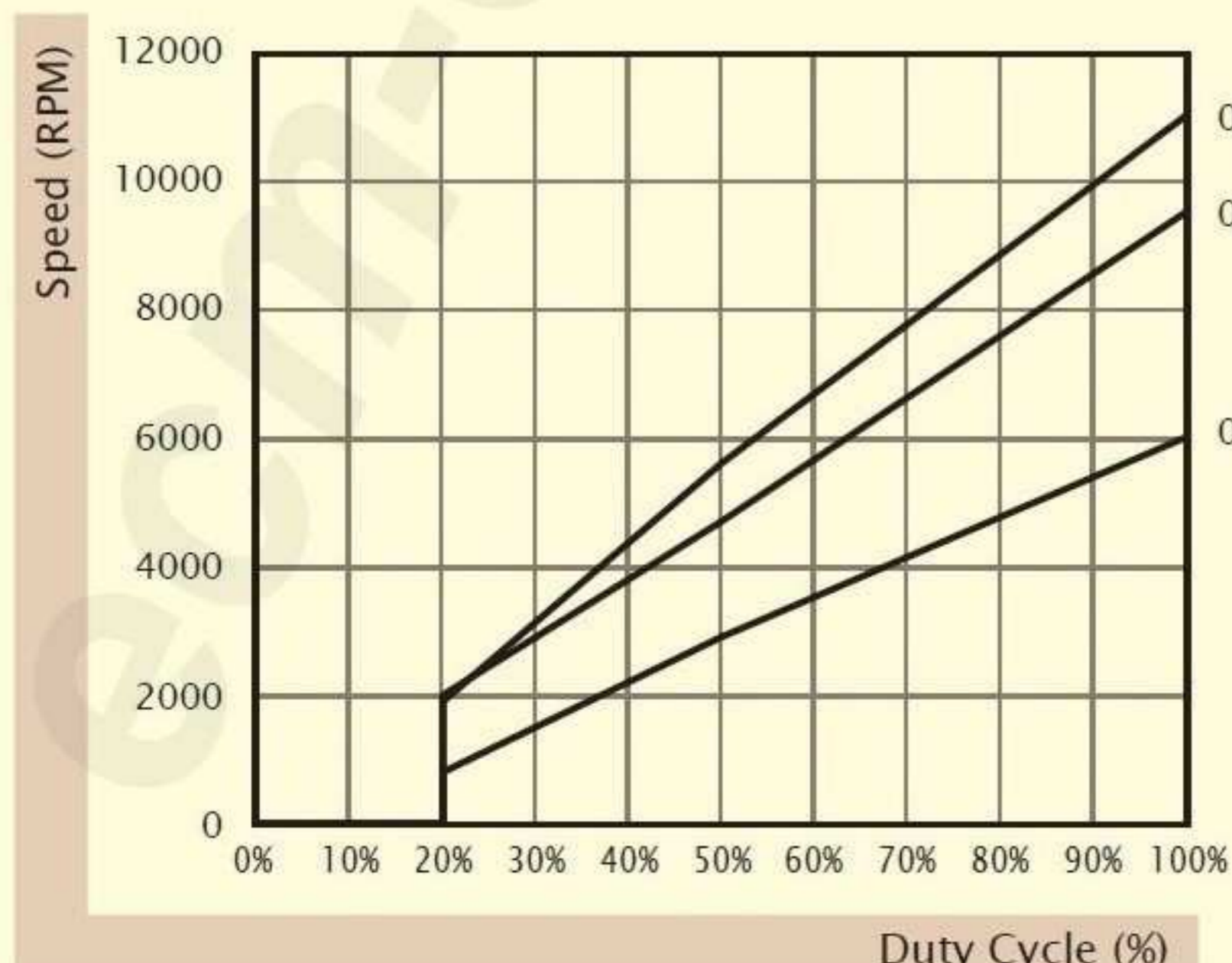

ECM Electronic
 Autoryzowany serwis spawarek oraz zgrzewarek krajowych i zagranicznych. Automatyka przemysłowa.
 Nasze strony: www.spaw-serwiszcz.pl * ecm-electronic.pl
 Dystrybucja, serwis, sprzedaż - kontakt:
 e-mail: spawserwiszcz@gmail.com, biuro@ecm-electronic.pl
 tel. kont.: +48 501 283 621, +48 34 368 1578 (z fax.)
