



ECM Electronic

Autoryzowany serwis spawarek oraz zgrzewarek krajowych i zagranicznych. Automatyka przemysłowa.



Wentylator: AC; osiowy; 230VAC; 172x150x38mm; 282,2m³/h; 50dBA

UF15A23BTH

Oznaczenie producenta: UF15A23BTH

Symbol **ECM**: UF15A23-H

SPECYFIKACJA



UF-15A23BTH

230VAC 50/60 Hz
37W/0,25A
50dBA

Producent	FULLTECH
Typ wentylatora	AC
Rodzaj wentylatora	osiowy
Rozmiar wentylatora	172x150x38mm
Pobór mocy	37W
Prąd znamionowy	0,25A
Wydajność wentylatorów	282,2m ³ /h
Poziom hałasu	50dBA
Rodzaj łożyska	kulkowe
Prędkość obrotowa	2750obr./min
Częstotliwość	50...60Hz
Rezystancja izolacji min.	0,1GΩ
Materiał obudowy	aluminium
Wyprowadzenia	konektory
Temperatura pracy	-40...70°C
Ciśnienie statyczne	11mm H ₂ O



Typ AC
282,2m³/h
2750obr./min
11mm H₂O
-40...70°C
Obudowa aluminium
172 x 150 x 38mm/788,9 g
Łożyska kulkowe

ecm-electronic.pl spaw-serwisz.pl



Napięcie zasilania • 230V AC

Masa brutto 788.9 g

Sposób pakowania Tacka = 10 szt
Karton = 20 szt



SPECIFICATIONS

FULLTECH ELECTRIC CO.,LTD

MODEL	UF-15A23-H
RATED VOLTAGE	AC230V
VOLTAGE RANGE	AC207-253V
SPEED(RPM)	50Hz 2750 RPM±10% 60Hz 3200 RPM±10%
RATED CURRENT	50Hz 0.25 A±10% 60Hz 0.19 A±10%
RATED INPUT	50Hz 39 W±10% 60Hz 31 W±10%
LOCKED CURRENT	50Hz 0.320 A±10% 60Hz 0.280 A±10%
MAX. AIR VOLUME	50Hz 166±10% CFM 60Hz 198±10% CFM
MAX. STATIC PRESSURE	50Hz 0.43±10% inH ₂ O 60Hz 0.40±10% inH ₂ O
OPERATING TEMP.	-40°C~+70°C
MAX. OPERATING HUMIDITY	85%
STORAGE TEMP.	-40°C~+80°C
ROTATING DIRECTION	ANTI-CLOCKWISE DIRECTION
BLOWING DIRECTION	EXHAUST OVER STRUTS
INSULATION RESISTANCE	DC 500 V 100MΩ
DIELECTRIC STRENGTH	AC 1500V / 1MIN.
NOISE	50Hz 50 dB±10% 60Hz 55 dB±10%
SAFETY PROTECTION	IMPEDANCE PROTECTION
INSULATION GRADE	CLASS B
BEARING	BALL BEARING
LIFE EXPECTANCY	OVER 40000 HOURS (40°C)
FRAME MATERIAL	ALUMINUM (ADC-12)
IMPELLER	PLASTIC 94V-0 PBT. COVERING GLASS FIBER
DIMENSION	172*150*38 mm
WEIGHT	0.78 KG.

表單編號: QP 1125-08-4.0

2016/7/21



UF - 15A23B - H

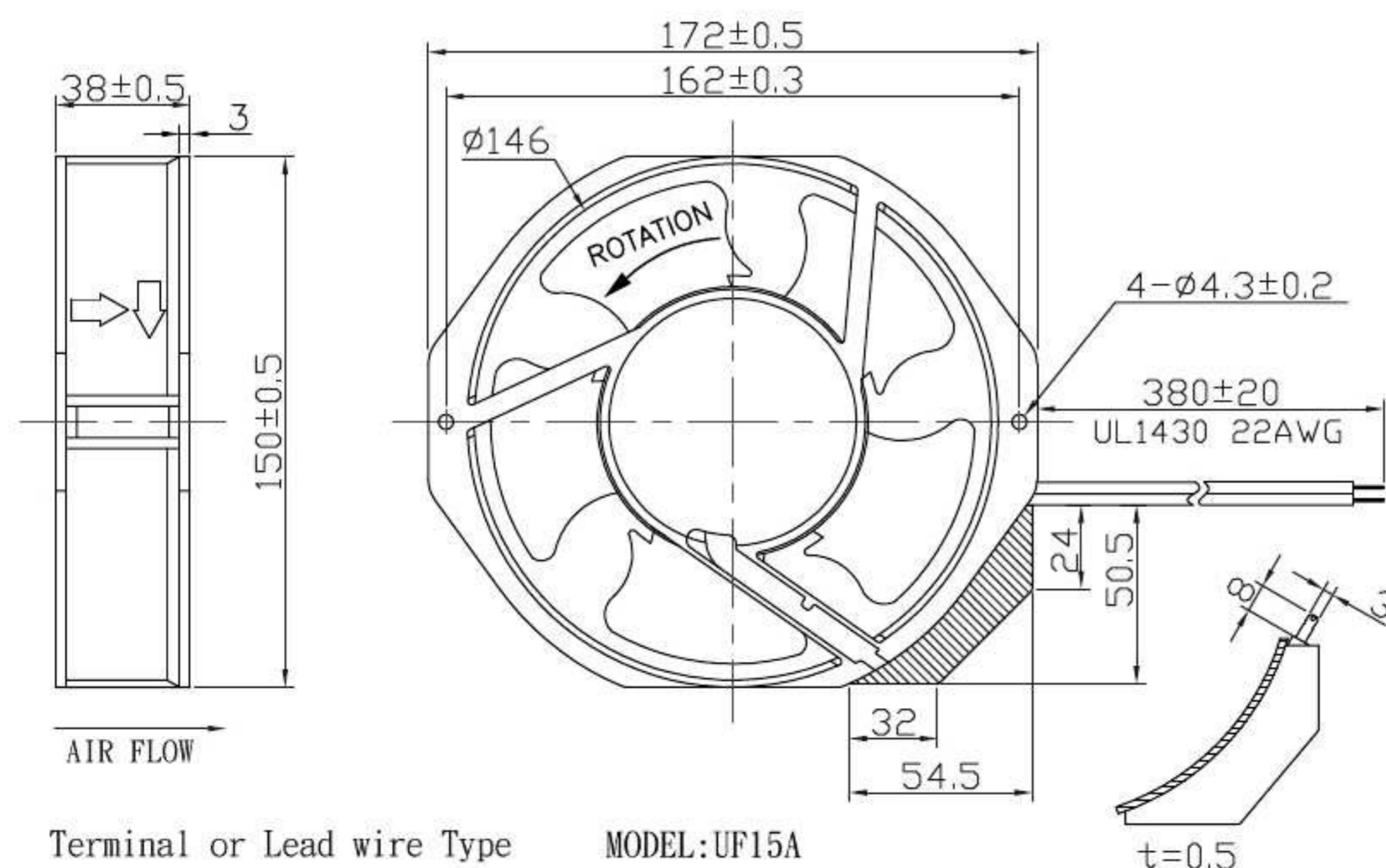
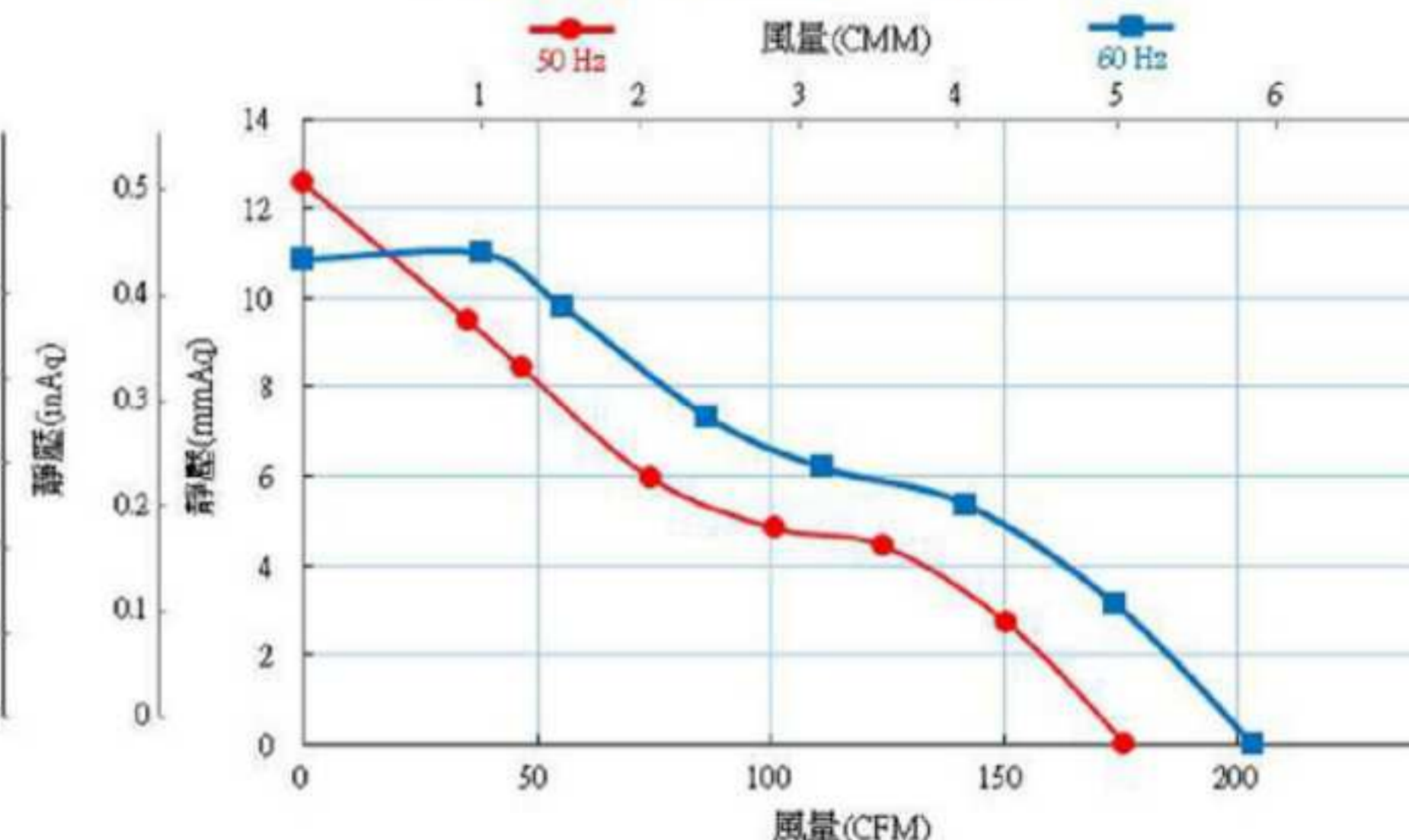

Terminal or Lead wire Type MODEL:UF15A



Nasze strony: www.spaw-serwisz.pl * ecm-electronic.pl

Dystrybucja, serwis, sprzedaż - kontakt:

e-mail: spawserwisz@gmail.com, biuro@ecm-electronic.pl

tel. kont.: +48 501 283 621, +48 34 368 1578 (z fax.)